

REV	DATE	DESCRIPTION

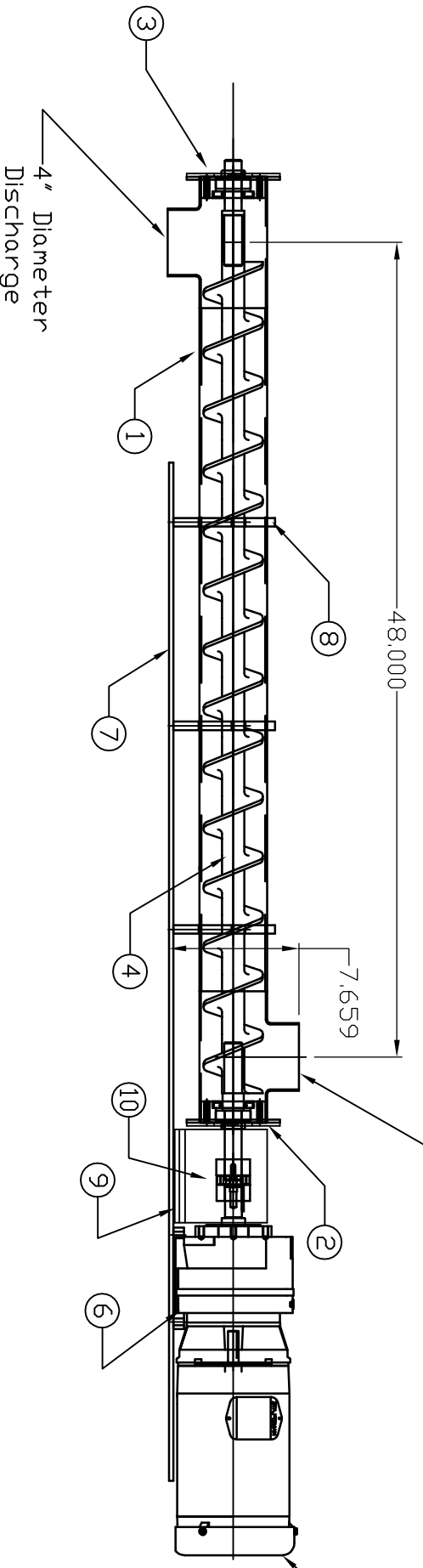
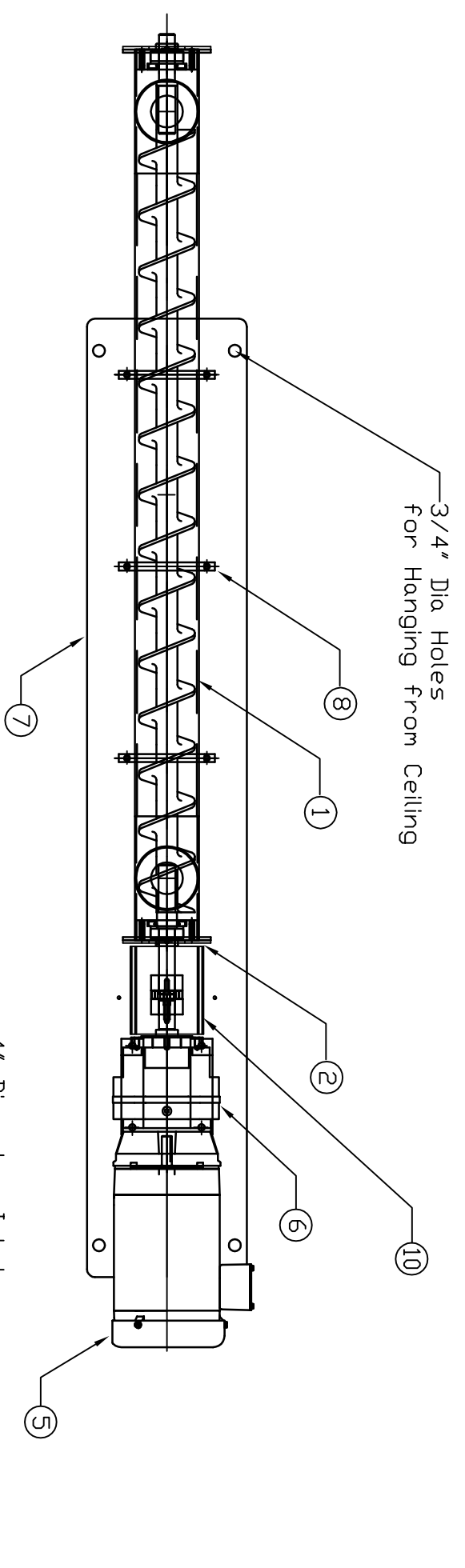

Assembly Drawing / Do Not Scale Drawing
Dimension / Scaling are Close Approximation
For More Detail See Individual Drawings
Hidden Views are Shown for General Arrangement

IT.	QUAN	DESCRIPTION	PART NO.	MATERIAL
10	1	Guard Main Drive Shaft, Top	BD-10052-03	6061 Aluminum
9	1	Guard Main Drive Shaft, Mount	BD-10052-04	6061 Aluminum
8	3	4" Tube Clamp	BD-10189-00	6061 Aluminum
7	1	Base Plate, 4" Tube Feeder	BB-10190-00	304 Stainless Steel
6	1	Gear Reducer, 22:1	BP-10054-06	.
5	1	Drive Motor, 1-1/2 Hp	BP-10049-11	.
4	1	Auger, 3-1/2" OD by 3/12" P	BR-10133-01	304 Stainless Steel
3	1	Assembly, Bearing for Idler End	BS-10107-01	.
2	1	Assembly, Bearing for Drive	BS-10107-00	.
1	1	4" Tube Feeder, 48" Center	BD-10072-04	304 Stainless Steel

AUGER Feeders, LTD.
325 Westtown Road
West Chester, Pennsylvania 19382 USA
(610) 692-7290 voice
(610) 692-7282 fax

TITLE: ASSEMBLY: Tube Feeder, 4.0" Diameter
48" Port Centers

FIRST USED	DRAWN BY	REV.	DRAWING NO.
	JET		BA-10234-00
ASSEM. DRWG NO.	CHK'D BY	DATE	SHEET 1 OF 1
		5/7/08	

CONFIDENTIAL INFORMATION
THIS DRAWING AND ALL INFORMATION CONTAINED THEREIN IS THE REMAINS THE PROPERTY OF AUGER FEEDERS, Ltd. AND IS CONFIDENTIAL. IT IS SUBMITTED AND MAY BE USED ONLY IN CONNECTION WITH AUGER FEEDERS PROPOSAL AND / OR ITS CUSTOMER'S ORDERS. IT SHALL NOT BE DISCLOSED TO OTHERS OR COPIED WITHOUT AUGER FEEDERS SPECIFIC WRITTEN CONSENT AND SHALL BE IMMEDIATELY RETURNED TO AUGER FEEDERS LTD. UPON REQUEST.

DO NOT SCALE PRINT
UNLESS NOTED OTHERWISE ALL DIMENSIONS ARE IN INCHES: TOLERANCES ARE AS FOLLOWS:
FRACTIONAL DECIMALS ANGLES
6" LESS ±1/32 X ±.03 INCLUDES
8" OVER ±3/32 .XX ±.01 IMPLIED 90°
XXX ±.005
REMOVE ALL BURRS AND SHARP EDGES